

CEE 7/VII

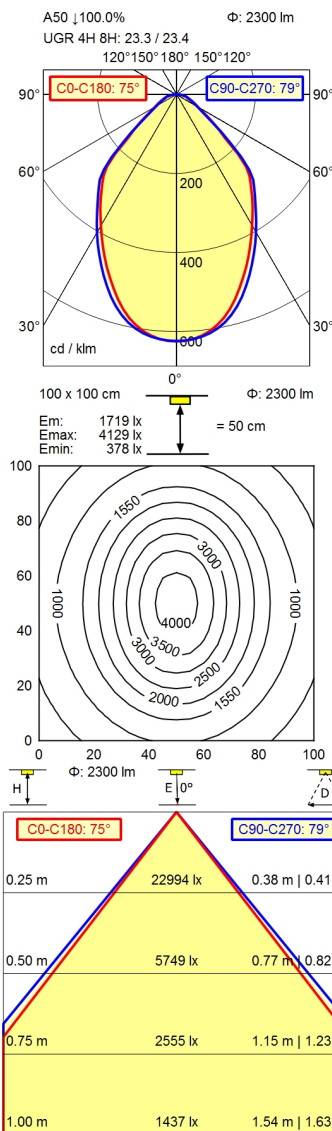

- light source
- work equipment
- connected load
- power consumption
- luminous flux
- luminous efficiency
- light type/-color
- colour temperatur
- color rendering index
- light distribution
- direct ratio
- beam angle
- chromaticity tolerance LED
- glare control
- luminance (L65)
- unified glare rating (4H 8H)
- system of protection
- class of protection
- technology
- operation
- housing
- cover
- weight (net)
- mains lead
- design
- fastening
- special features

- LED
- electronic transformer
- 100-240 V, 50/60 Hz; secondary 24 V, DC
- env. 30 W
- approx. 2.300 lm
- approx. 88 lm/W
- cold white
- approx. 4.000 K
- CRI > 90; R9 > 50
- direct
- approx. 100 %
- 75°
- < 3 SDCM
- conical prismatic screen
- <= 12000 cd/m<sup>2</sup>
- <= 25
- IP 20
- I with plug-in power supply; III without plug-in power supply
- continuously dimmable; Touch DIM
- multi-function switch
- sectional aluminium; anodised; aluminium
- coloured anodised
- structured; plastic
- env. 1,8 kg
- ca. 4,50 m; mains plug; CEE 7/III
- mounted version
- screw-down bracket, horizontal
- fixed connection

